

TAG: \_\_\_\_\_

# SUBMITTAL

## 1.5 Ton Split System Air Conditioner - 1 Phase J5AC5018A1000AA

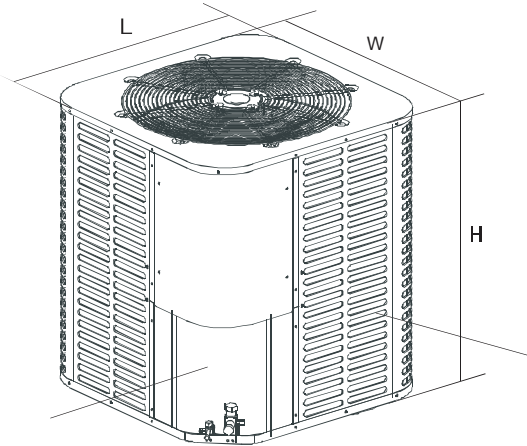

**AIR INLETS**  
LOUVERED PANELS  
ALLOW 12"  
MINIMUM  
CLEARANCE

**SERVICE ACCESS**  
ALLOW 24" CLEARANCE

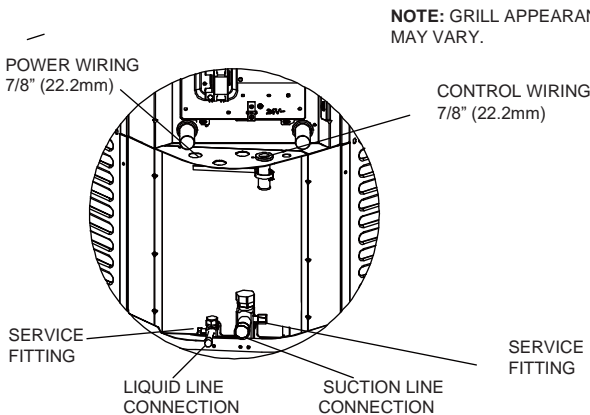

### Product Specifications

OUTDOOR UNIT	J5AC5018A1000AA
POWER CONNS. — V/PH/HZ	208/230V/1Ph/60Hz
MIN. BRCH. CIR. AMPACITY	12.2
BR. CIR. PROT. RTG. - MAX. (AMPS)	15
COMPRESSOR	Rotary
NO. USED - NO. SPEEDS	1 - 1
VOLTS/PH/HZ	208-230/1/60
R.L. AMPS - L.R. AMPS	9.0-39
FACTORY INSTALLED START COMPONENTS	No
INSULATION/SOUND BLANKET	No
COMPRESSOR HEAT	No
RATED SOUND POWER LEVEL(dB)	73
OUTDOOR FAN/MOTOR	PROPELLER/ECM
DIA. (IN.) - NO. USED	18-7/8 - 1
TYPE DRIVE - NO. SPEEDS	EXTERNAL - 10
CFM @ 0.0 IN. W.G.	1880
NO. MOTORS - HP	1 - 1/6
MOTOR SPEED R.P.M	930
VOLTS/PH/HZ	208/230V/1Ph/60Hz
F.L. AMPS	0.90
OUTDOOR COIL — TYPE	Microchannel
ROWS - F.P.I.	1-23
FACE AREA (SQ. FT.)	10.00
TUBE SIZE (IN.)	/
REFRIGERANT	
LBS. — R-454B (O.D. UNIT)	3 LBS.-4 OZ.
FACTORY SUPPLIED	YES
LINE SIZE - IN. O.D. GAS	3/4
LINE SIZE - IN. O.D. LIQ.	3/8
CHARGING SPECIFICATION	
SUPERHEAT	See Installation Manual
DIMENSIONS	W x H x L
CRATED (IN.)	24-7/10x26-1/4x24-7/10
WEIGHT	
SHIPPING (LBS.)	116
NET (LBS.)	102

NOTE: All dimensions are in inches.

Model	W	H	L	GAS VALVE SIZE	LIQUID VALVE SIZE
J5AC5018A1000AA	23-5/8	24-15/16	23-5/8	3/4	3/8

# Mechanical Specification Options

---

## **General**

The J5AC50 is fully charged from the factory for 15ft of lineset. This unit is designed to operate at outdoor ambient temperatures as high as 115°F. Cooling capacities are matched with air handlers and furnace coils that are AHRI certified. The unit is certified to ETL. Exterior is designed for outdoor application.

## **Casing**

Unit casing is constructed of heavy gauge, Galvanized steel and painted with a weather-resistant powder paint on all grilles, panels, pre-paint on all other panels. And had 500-hours salt spray tested.

## **Refrigerant Controls**

Refrigeration system controls include condenser fan, compressor contactor.

## **Compressor**

Features include low vibration and noise.

## **Condenser Coil**

The outdoor coil provides low airflow resistance and efficient heat transfer. The coil is protected on all four sides by grille panels. The coil has a hydrophilic coating.

## **Optional accessories**

### **via 3<sup>rd</sup> party -Liquid**

### **Line Drier**

It is used to filter out impurities and water in the system, ensures system clean and dry.



*OXBOX has a policy of continuous product and product data improvement and it reserves the right to change design and specifications without notice.*

**BX-PRQ-J5AC5018A1000AA-1A**